

Date	SYM	REVISION RECORD	AUTH	DR.	CK.
5/22/09	A	ADDED TEST RESULTS	T.B.	B.S.	

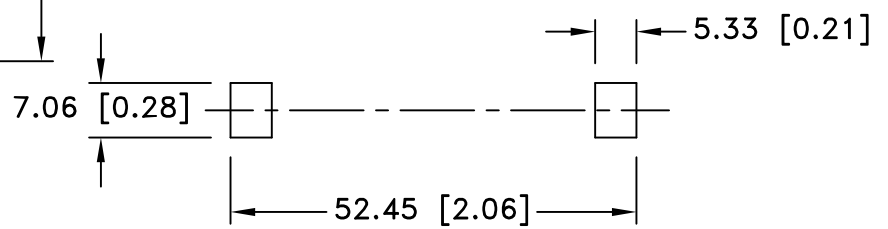

PCB LAYOUT

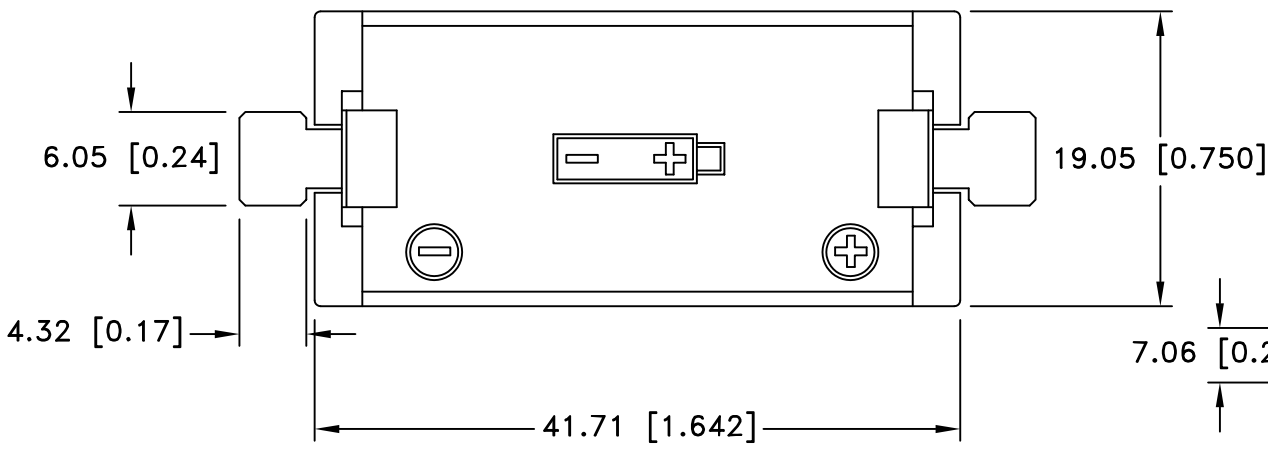
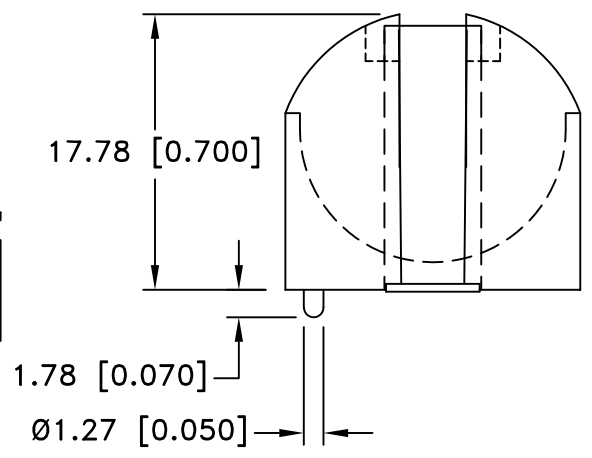
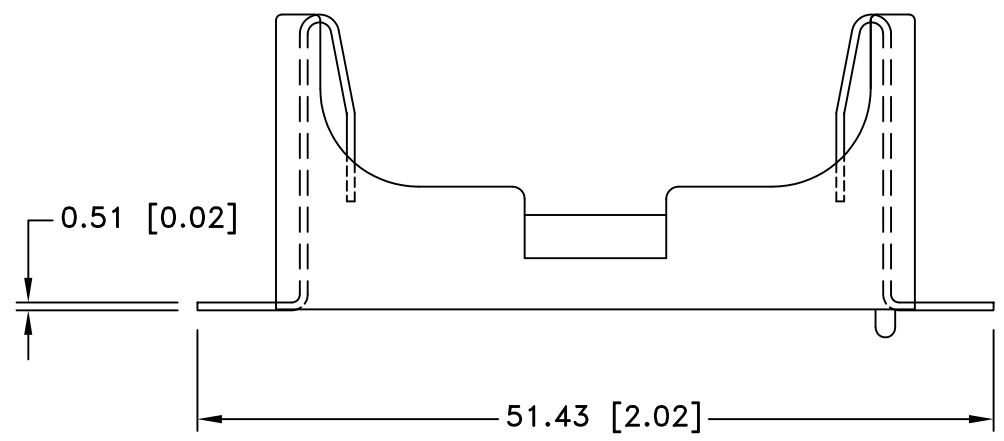

SPECIFICATIONS:

- HOLDER MATERIAL: NYLON 46, 30% GLASS REINFORCED
- FLAMABILITY RATING:UL94-HB, FILE #E47960
- CONTACTS: 301 SPRING TEMPER STAINLESS STEEL, GOLD FLASH 1u -3u
- TEMPERATURE RANGE: -40°C TO +270°C
- \* VIBRATION TEST: 10-50-10 HZ SWEEPED IN 60 SECONDS  
X,Y,Z DIRECTION: 1 HOUR EACH DIRECTION
- \* RESULT: NO DISLODGE MENT OF THE CELL OR DAMAGE  
NO DISCONTINUITY OVER 10 MICRO-SECONDS
- \* SHOCK TEST: HALF SINE WAVE ACCELERATION 150G. 6 MICRO-SECONDS  
3 SHOCK PULSES EACH DIRECTION PER AXIS, TOTAL OF 18 PULSES
- \* RESULT: NO EVIDENCE OF PHYSICAL DAMAGE
- \* DROP TEST: DROPE D FROM 1M HIGH TO CONCRETE FLOOR
- \* RESULT: NO EVIDENCE OF PHYSICAL DAMAGE

ROHS COMPLIANT

Tolerance (Except as noted)	 <b>Memory Protection Devices, Inc</b> 200 Broad Hollow Road, Farmingdale, New York 11735	Scale	Drawn By B.S.
			Approved By T.B.
decimal ±.5 (.020)	Title 2/3A BATTERY HOLDER, PCB MOUNTING		
Fractional ± .8 (.030)		Date 5/22/09	Drawing Number BH2/3A-SM
Angular ± 3°			